

QLS65T

SPECIFICATIONS

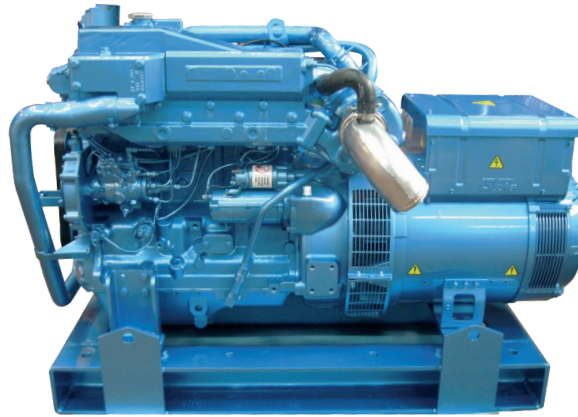

Frequency	50 Hz	Engine base	John Deere
Voltage	400 V	Cooling system	Seawater pump with rubber impeller
Amperes	73 A cont. 81 A max.	Closed cooling	Heat exchanger
Power	52 kW cont. 57.2 kW max.	Cylinders	4 in line
Protection	IP23	Start (cold temperature)	Super Glow System
Insulation	Class H	Exhaust connexion	102 mm [4 in]
Voltage accuracy	± 0.5%	Fuel consumption at full load	8.0 l/h [2.11 gal US/h]
Radio interference	Deleted	Sea water pump connexion	32 mm [1.3 in]
Lenght	1510 mm [59.4 in]	Fuel pump - Max suction height	std pump : 0.5 m [19.7 in] with add. pump : 1.8 m [70.9 in]
Width	822 mm [32.4 in]	Engine operating angle	15° cont. 30° max.
Height	1050 mm [41.3 in]	Fuel connexion	10 mm [0.4 in]
Dry weight	852 kg [1878.3 lbs]		

QLS65T

57.2 kW max at 1500 rpm

TECHNICAL DESCRIPTION

ENGINE BASE

- 4 strokes Diesel engine tested in all marine or industrial applications throughout the world.
- Replaceable wet-type cylinder liners giving an excellent heat dissipation for long life.
- Internal balancer.

INJECTION AND COMBUSTION SYSTEM

- Proven and reliable Mechanical Governor
- High torque and low rated rpm
- Electronically controlled rotary fuel injection pump with variable timing resulting in excellent fuel economy and excellent performance
- Self diagnostics and protection

COOLING SYSTEM

- Cooling is ensured by heat exchange between coolant and seawater in an heat exchanger, or via a Keel Cooling system.
- Reduced external connections eliminates hoses and fittings that can leak or break.
- Cooler and quieter environment for vessel and crew.
- Seawater pump with rubber impeller.

GENERATOR

- Delivering a continuous power of 52 kW and able to provide up to 57.2 kW
- IP23 protection

STANDARD EQUIPMENT

- Extension delivered by meter
- Closed cooling with heat exchanger
- Wet exhaust
- 24V Single-pole electrical system
- Safety shutdowns on low oil pressure and high coolant temperature
- Luxe GE panel
- Rubber mounts
- Oil drain pump mounted on the engine

OPTIONAL EQUIPMENT

- Seawater hoses
- Seawater filter
- Siphon breaker
- Fuel feed system piping
- Exhaust system
- Fuel prefilter
- Keel Cooling
- Vertical dry exhaust
- 24V Double-pole electrical system
- Additional electric fuel feed pump

INSTRUMENT PANEL

LUXE GE



- Start and stop buttons
- Low oil pressure warning light
- Coolant temperature warning light
- Preheat warning light
- Battery charge warning light
- Oil pressure indicator
- Coolant temperature indicator

MAIN COMPONENTS

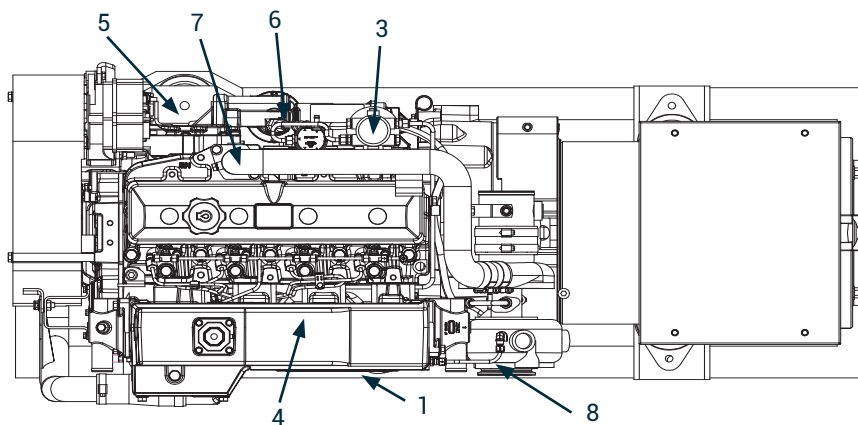

- | | |
|-------------------|------------------|
| 1. Oil drain pump | 5. Seawater pump |
| 2. Fuel feed pump | 6. Oil filter |
| 3. Fuel filter | 7. Air filter |
| 4. Expansion tank | 8. Exhaust elbow |

NANNI INDUSTRIES S.A.S.

11, Avenue Mariotte - Zone Industrielle
33260 La Teste - France
Tel: +33 (0)5 56 22 30 60
Fax: +33 (0)5 56 22 30 79

Technical data according to ISO 8528. This document is not contractual. Nanni reserves the right to modify any of the characteristics stated in this document without notice, in a constant effort to improve the quality of its products. Images and illustrations may show non standard equipments. All combination of equipment & accessory are not available.

DGBXXC01167